DISTRIBUTION SOLUTIONS

LVS Digital with UMC Motor Controller Interface Manual Profibus



NOTICE

This document contains information about one or more ABB products and may include a description of or a reference to one or more standards that may be generally relevant to the ABB products. The presence of any such description of a standard or reference to a standard is not a representation that all of the ABB products referenced in this document support all of the features of the described or referenced standard. In order to determine the specific features supported by a particular ABB product, the reader should consult the product specifications for the particular ABB product.

ABB may have one or more patents or pending patent applications protecting the intellectual property in the ABB products described in this document.

The information in this document is subject to change without notice and should not be construed as a commitment by ABB. ABB assumes no responsibility for any errors that may appear in this document.

Products described or referenced in this document are designed to be connected and to communicate information and data through network interfaces, which should be connected to a secure network. It is the sole responsibility of the system/product owner to provide and continuously ensure a secure connection between the product and the system network and/or any other networks that may be connected.

The system/product owners must establish and maintain appropriate measures, including, but not limited to, the installation of firewalls, application of authentication measures, encryption of data, installation of antivirus programs, and so on, to protect these products, the network, its system, and interfaces against security breaches, unauthorized access, interference, intrusion, leakage, and/or theft of data or information.

ABB performs functionality testing on the products and updates that we release. However, system/product owners are ultimately responsible for ensuring that any product updates or other major system updates (to include but not limited to code changes, configuration file changes, third-party software updates or patches, hardware change out, and so on) are compatible with the security measures implemented. The system/product owners must verify that the system and associated products function as expected in the environment in which they are deployed.

In no event shall ABB be liable for direct, indirect, special, incidental or consequential damages of any nature or kind arising from the use of this document, nor shall ABB be liable for incidental or consequential damages arising from use of any software or hardware described in this document.

This document and parts thereof must not be reproduced or copied without written permission from ABB, and the contents thereof must not be imparted to a third party nor used for any unauthorized purpose.

The software or hardware described in this document is furnished under a license and may be used, copied, or disclosed only in accordance with the terms of such license. This product meets the requirements specified in EMC Directive 2014/30/EU and in Low Voltage Directive 2014/35/EU.

TRADEMARKS

MNS is a registered or pending trademark of ABB.

Ability is a trademark of ABB.

All rights to copyrights, registered trademarks, and trademarks reside with their respective owners.

Copyright © 2021 ABB.

All rights reserved.

Release: January 2021

Document Number: 1TGC908004

Revision: M0204

Table of Contents

1. General	1
1.1. Target Group.....	1
1.2. Use of Warning, Caution, Information and Tip icon.....	1
1.3. Terminology.....	2
1.4. Related Documentation.....	5
1.4.1 PROFIBUS additional guidelines.....	5
2. Introduction	6
2.1 Hardware Types and Technical Data.....	7
2.2 PROFIBUS Standard.....	8
2.3 PROFIBUS DP-V0.....	8
2.3.1 Cyclic Data Communication.....	8
2.3.2 Diagnostic.....	9
2.3.3 Sync and Freeze Mode.....	9
2.3.4 DP Master Class 1 (DPM1) and Class 2 (DPM2).....	9
2.3.5 Monitoring the DP-V0 Communication.....	9
2.4 PROFIBUS DP-V1.....	10
2.4.1 Acyclic Data Communication.....	10
3. Interfaces	11
3.1 Front View.....	11
3.2 Power Supply.....	13
4. Digital Gateway Installation	14
4.1 Digital Gateway Mounting.....	14
4.2 CF Card Installation.....	15
5. Communication Interface Connection	16
5.1 Switchgear Bus Network.....	16
5.2 Switchgear Control Network.....	17
5.2.1 Connection Examples of Switchgear Control Network.....	18
5.3 Time Synchronization.....	20
5.3.1 Option 1.....	20
5.3.2 Option 2.....	21
5.4 Fieldbus.....	22
5.4.1 PROFIBUS.....	22
6. Redundancy	24
6.1 Redundant Architecture.....	24
6.2 Redundancy Configuration.....	25
6.2.1 Redundant Digital Gateway connection.....	25
6.2.2 Digital Gateway Redundant Configuration.....	26
6.3 Handling of redundancy faults.....	28
6.4 MView / Web Interface.....	29
7. Configurations	30
7.1 Initial Values – IP Configuration.....	30
7.2 Settings – IP Configuration.....	31
7.2.1 Definition of IP Addresses.....	32
7.3 Settings – PROFIBUS Communication.....	33
7.4 Addressing.....	34
7.5 Failsafe.....	35
7.6 Start-up of Digital Gateway and application download.....	35

7.6.1	Power-On procedure	35
7.6.2	Power On the control voltage supply	35
7.6.3	Confirm operation	35
8.	Data Mapping	36
8.1	User Data Map	36
8.2	Default Data Map	36
8.2.1	Cyclic Data Communication (DP-V0)	37
8.2.2	Status Bit Explanation	38
8.2.3	Commands (Output to field device from master).....	39
8.2.4	Command Bits Explanation	40
8.2.5	Handling of Commands and Priority	41
8.2.6	Redundant Digital Gateway Profibus Data.....	42
8.2.7	Control Access	43
8.2.8	Acyclic Data Communication (DP-V1 –master class 1)	45
9.	Troubleshooting and Maintenance	49
9.1	Digital Gateway LED Indication	49
9.2	Troubleshooting.....	52

List of Figures

Figure 1: Digital Gateway	6
Figure 2: LVS Digital System Configuration with UMC.....	6
Figure 3 Cyclic User Data Transmission in DP.....	8
Figure 4 Acyclic Communication in DP-V1: Read Service.....	10
Figure 5 Digital Gateway front view	11
Figure 6 Power Supply Connector	13
Figure 7 Digital Gateway Mounting Kit.....	14
Figure 8 CF Card Insertion.....	15
Figure 9 CF Card Insertion Detail.....	15
Figure 10 Different hardware connections possible between Digital Gateway and MTQ22	16
Figure 11 Digital Gateway directly connected to LVS Digital Edge Gateway.....	18
Figure 12 Network connection of Digital Gateway and LVS Digital Edge Gateway.	19
Figure 13 Example, showing 3rd party Network Switch and 3rd party NTP Server in a Switchgear Control Network	20
Figure 14 Example, using Digital Gateway as NTP Server	21
Figure 15 Digital Gateway PROFIBUS connection and termination examples.....	22
Figure 16 Redundancy configuration and possible failure scenario	24
Figure 17 Serial 1 to serial 1 redundant link connections with ferrite core	25
Figure 18 MNavigate IP address Parameterization for Primary and Backup Digital Gateway ..	26
Figure 19 MNavigate Fieldbus Slave address Parameterization for Primary and Backup Digital Gateway	27
Figure 20 MView Redirecting to Redundant Digital Gateway.....	29
Figure 21 Redundancy error shown in MView by a red square	29
Figure 22 IP Address Settings.....	31
Figure 23 Time Sync Settings.....	31
Figure 24 Parameter Window for PROFIBUSDP parameters in MNavigate.....	33
Figure 25 Example of max address range and slave numbers on one PROFIBUS Master	34
Figure 26 Mapping Selection from MNavigate	37

List of Tables

Table 1 Digital Gateway Profibus Hardware	7
Table 2 Digital Gateway Technical Data	7
Table 3 Front View Connectors, LED and Push Buttons	12
Table 4 Maximum segment cable length for RS485	23
Table 5 Maximum stub length for RS485	23
Table 6 Serial Redundant Link Cable ordering code	25
Table 7 Primary and Backup IP address setting	26
Table 8 Primary and Backup IP address setting	28
Table 9 Digital Gateway Default Parameters – IP Configuration	31
Table 10 Digital Gateway Default Parameters – PROFIBUS configuration	33
Table 11 244 Byte Cyclic Data Structure	37
Table 12 Monitoring Data Structure of a single UMC	37
Table 13 Explanation of status bit	39
Table 14 122 Byte cyclic Data Structure	39
Table 15 Command Data Structure of UMC.....	39
Table 16 Command Data Bits Explanation	40
Table 17 Redundant data for monitoring by the Profibus master	42
Table 18 Redundant Command possible from the Profibus Master	42
Table 19 Command and Status for Control Access	43
Table 20 Default DP-V1 data	46
Table 21 Extended Status Byte 58.....	46
Table 22 Extended Status Byte 59	47
Table 23 Extended Status Byte 60	47
Table 24 Extended Status Byte 61.....	48
Table 25 Digital Gateway LED indication.....	51
Table 26 Digital Gateway Troubleshooting.....	53

1. General

1.1. Target Group

This document describes communication and control interfaces used in LVS Digital (includes LVS Digital and NeoGear Digital switchgear) and LVS Digital Upgrade (upgrade from INSUM1 / 2) projects utilizing ABB motor controller UMC [supported from UMC100.3 onwards].

The manual is primarily intended for those requiring information on how to access information and data provided from Digital Gateway.

Furthermore, the document provides information for control system and application engineers how to integrate LVS Digital [Upgrade] as Fieldbus component into PLC or higher-level Process Control Systems.

It is assumed that the reader of this manual is familiar with basic terms of Fieldbus and control communication (e.g. basic knowledge about Modbus etc.).

1.2. Use of Warning, Caution, Information and Tip icon

This publication includes **Warning**, **Caution**, and **Information** icons where appropriate to point out safety related or other important information. It also includes **Tip** icons to point out useful hints to the reader. The corresponding symbols should be interpreted as follows:



The electrical warning icon indicates the presence of a hazard that could result in *electrical shock*.



The warning icon indicates the presence of a hazard that could result in *personal injury*.



The caution icon indicates important information or warnings related to the concept discussed in the text. It might indicate the presence of a hazard that could result in *corruption of software or damage to equipment/property*.



The information icon alerts the reader to pertinent facts and conditions.



The tip icon indicates advice on, for example, how to design your project or how to use a certain function.

Although **Warning** notices are related to personal injury, and **Caution** notices are associated with equipment or property damage, it should be understood that the operation of damaged equipment could, under certain operational conditions, result in impaired process.

performance leading to personal injury or death. It is therefore, imperative that you comply fully with all **Warning** and **Caution** notices.

1.3 Terminology

List of the terms, acronyms, abbreviations and definitions that the document uses.

Abbreviation	Term	Description
	Alarm	Alarm is defined as status transition from any state to abnormal state. Status transition to abnormal state can be data crossing over the pre-defined alarm limit.
	Bus Local	A Control Access term describing that the UMC accepts its commands from a device on the switchgear control network, e.g. the Web Interface, MView.
COTS	Commercial off the shelf	Commercial off the shelf product, term to describe products available on the market, ready to use
DCS	Distributed Control System	See also PCS
Eth.	Ethernet	Ethernet is a local area network (LAN) technology. The Ethernet standard specifies the physical medium, access control rules and the message frames.
	Event	An event is a status transition from one state to another. It can be defined as alarm, if the state is defined as abnormal or as warning as a pre-alarm state.
FD	Field Device	Term for devices connected to the Fieldbus (e.g. motor control units or circuit breaker protection)
GSD file	Geräte Stamm Datei (German abbreviation)	A hardware description file for a PROFIBUS-DP or PROFIBUS-DP/V1 slave type
GPS	Global Positioning System	System to detect local position, universal time and time zone, GPS technology provides accurate time to a system
	Hardware Local	A Control Access term describing that the UMC accepts its commands from the Hardwired inputs, when the respective Local control input is set to true.

HMI	Human Machine Interface	Generic expression
LVS	Low voltage switch-gear	A factory built assembly built to conform with IEC 61439-1
UMC100	Universal Motor Controller	An intelligent motor controller for 3-phase AC induction motors combining the two classical functions of motor protection and motor management in a single device plus offering diagnostic and fieldbus communication
MCC	Motor Control Centre	Common term for switchgear used for motor control and protection.
MNavigate		Configuration and parameterization tool for LVS Digital
MNS		Modular Low Voltage Switchgear family from ABB
	MODBUS	Fieldbus communication protocol
	MODBUS RTU	Fieldbus communication protocol
	MODBUS TCP/IP	Fieldbus communication protocol based on Ethernet hardware
	Motor Starter	Consists of motor controller and electrical components to control and protect a motor, part of Motor Control Center
NeoGear		Modular Low Voltage Switchgear family from ABB
NLS	Native Language Support	Providing the ability to change the language of software tools in order to support native languages (English is basis, others are optional)
OPC		The industrial standard for exchange of information between components and process control application.
PLC	Programmable Local Controller	Low level control unit
RCU	Remote Control Unit	Local control unit with pushbutton and indicator to operate a device (e.g. motor) from field level.

	PROFIBUS-DP	Fieldbus communication protocol with cyclic data transfer (V0).
	PROFIBUS-DP/V1	Fieldbus communication protocol, extension of PROFIBUS- DP allowing acyclic data transfer and multi master (V1).
	PROFIBUS-DP/V2	Fieldbus communication protocol, extension of PROFIBUS- DP allowing time stamp and communication between master and slave (V2).
RS232		Standard No. 232 for PC communication, established by EIA (Electronics Industries Association, USA)
RS485		Communication interface standard from EIA (Electronics Industries Association, USA), operating on voltages between 0V and +5V. RS-485 is more noise resistant than RS-232C, handles data transmission over longer distances, and can drive more receivers.
RTC	Real Time Clock	Integrated clock function in devices used to generate time and date information if a remote clock system is not present
	Software Local	A Control Access term describing that the UMC accepts its commands from the hardwired inputs as a result of either the PCS or MView passing the Control Access Authority to Soft-Local. Note: Does not require the hardwired local input to be set to true.
SNTP	Simple Network Time Protocol	A protocol used for time synchronization in Control Network through Ethernet
	Switchgear Bus Network	Term used to describe the internal switchgear communication network, between Digital Gateway and UMC
TCP/IP	Transmission Control Protocol / Internet Protocol	TCP/IP is a high-level connection oriented, reliable, full duplex communication protocol developed for integration of the heterogeneous systems.
	Trip	A consequence of an alarm activated or an external trip command from another device to stop the motor or trip the circuit breaker.

UTC	Coordinated Universal Time	Coordinated Universal Time is the international time standard. It is the current term for what was commonly referred to as Greenwich Meridian Time (GMT). Zero (0) hours UTC is midnight in Greenwich England, which lies on the zero longitudinal meridian. Universal time is based on a 24-hour clock.
	Warning	A warning is defined as status transition from any state to pre-alarm state to inform in advance before an alarm level is reached.

1.4 Related Documentation

2CDC194003D0202	Technical Description FBP Fieldbus Plug MTQ-22FBP
1TGC908001	ABB Ability Condition Monitoring for electrical systems - CMES - User Manual
1TNA810039	Manufacturing Instruction - Installation of MService and MNS Digital Gateway in MNS
1TGC908028	LVS Digital Interface Manual Web Server

1.4.1 PROFIBUS additional guidelines

- PROFIBUS Installation Guideline, Rev 4, Nov 2002, PROFIBUS Competence Center Manchester, UK
- PROFIBUS Profiles for Low Voltage Switchgear Devices (LVSG), 3.122 Version 1.2 July 2006, PNO Karlsruhe, Germany
- PROFIBUS Installation Guideline for Cabling and Assembly, 8.022 Version 1.0.6 May 2006, PNO Karlsruhe, Germany
- PROFIBUS Installation Guideline for Commissioning 8.032 Version 1.0.2 November 2006 PNO Karlsruhe, Germany
- PROFIBUS Technology Description 4.002 Version October 2002 PNO Karlsruhe, Germany

2. Introduction

The Digital Gateway is an industrial PC equipped with interface cards and ports re-quired for communication internally to UMC and externally to process control systems as well as to the CMES Edge which provides condition monitoring features and functions as well as edge connectivity to ABB Ability™ cloud based solutions.



Figure 1: Digital Gateway

One Digital Gateway can communicate internally to up to 128 UMC / field devices by Modbus TCP. If more than 128 UMC / field devices are installed, then additional Digital Gateway have to be configured.

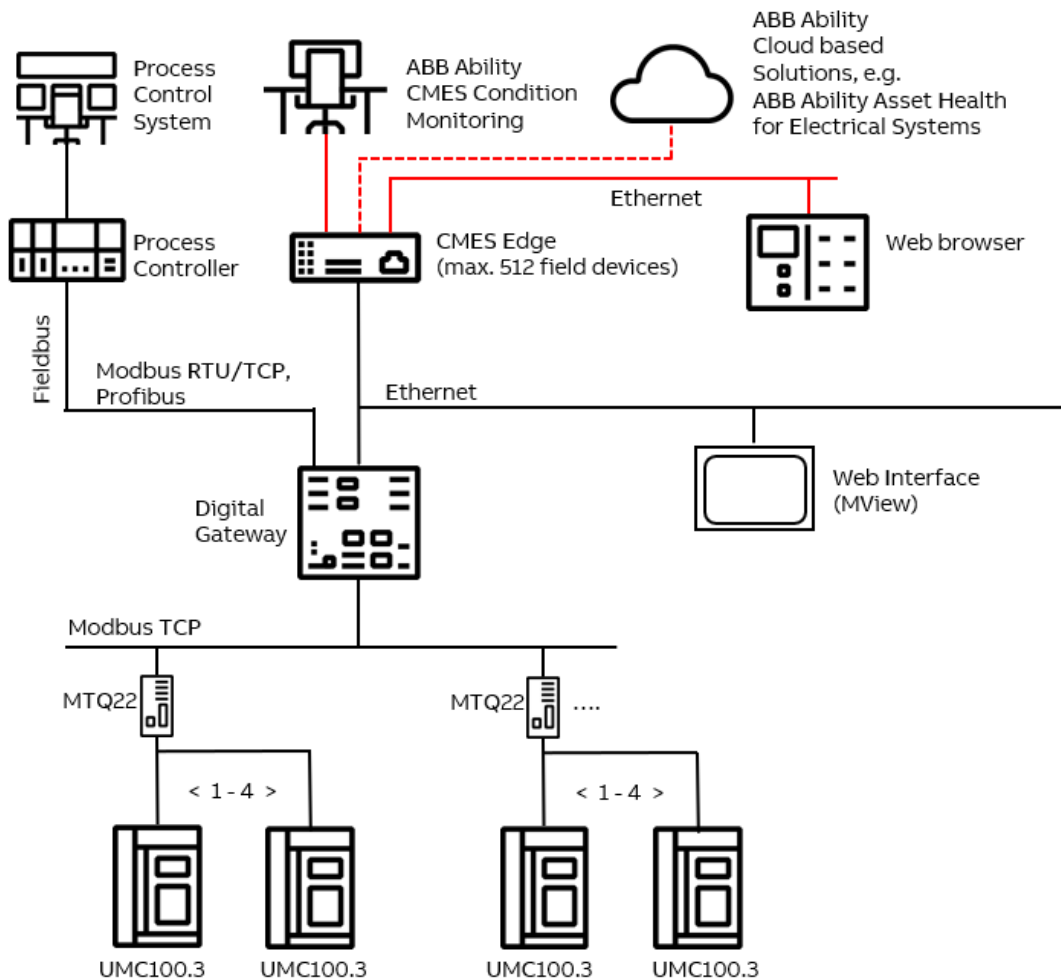

Figure 2: LVS Digital System Configuration with UMC

2.1 Hardware Types and Technical Data

The configuration of Digital Gateway depends on the selected communication protocol to the DCS. For the Profibus communication to DCS the hardware shown in the table below is applicable

Fieldbus Protocol	Profibus
Fieldbus Hardware Interface	Profibus DP V0, V1
Digital Gateway ID	1TGE120021R0710
Picture	

Table 1 Digital Gateway Profibus Hardware

For communication to UMC, Digital Gateway need to be connected to MTQ22-FBP via a dedicated Ethernet port (LAN 3) which has to be used dependent on system configuration (redundant, non-redundant system).

ELECTRICAL DATA	
Power Supply	24V DC (19 – 31V DC)
Power Consumption	Typical 800mA, maximum 1000mA
MECHANICAL DATA	
Weight	2.5 kg
Dimensions H x W x D	140 x 160 x 246 mm
ENVIRONMENTAL DATA	
Storage Temperature	-20°C to + 70°C
Operating Temperature	0°C to 55°C
Degree of Protection	IP51
MTBF (Mean Time Between Failures)	46 years @ 40°C

Table 2 Digital Gateway Technical Data

2.2 PROFIBUS Standard

PROFIBUS is a manufacturer-independent Fieldbus standard for applications in manufacturing, process and building automation. PROFIBUS technology is described in fixed terms in DIN 19245 as a German standard and in EN 50170 / IEC 61158 as an international standard. The PROFIBUS standard is thus available to every provider of automation product.

The PROFIBUS family is composed of three types of protocol, each of which is used for different tasks. Of course, devices with all three protocols can communicate with each other in a complex system by means of a PROFIBUS network.

The three types of protocols are: PROFIBUS FMS, DP and PA. Only the two protocol types DP and PA are important for process automation, whereas only DP is used in LVS Digital

PROFIBUS DP: **PRO**cess **FI**eld**bus** for the **D**ecentralized **P**eriphery

The PROFIBUS DP (RS 485) is responsible for communication between the Controller level of a process automation system and the decentralized periphery in the field. One feature of PROFIBUS DP is its high speed of transmission up to 12 Mbit/s.



Digital Gateway supports transmission speed up to 1.5 Mbit/s only.

2.3 PROFIBUS DP-V0

2.3.1 Cyclic Data Communication

The data communication between the DPM1 (DP Master Class 1) and its assigned slaves is automatically handled by the DPM1 in a defined, recurring sequence. With each user data transfer, the master can write up to 244 bytes of output data to the slave and read up to 244 bytes of input data from the slave. The Data is read and written synchronously in one procedure.

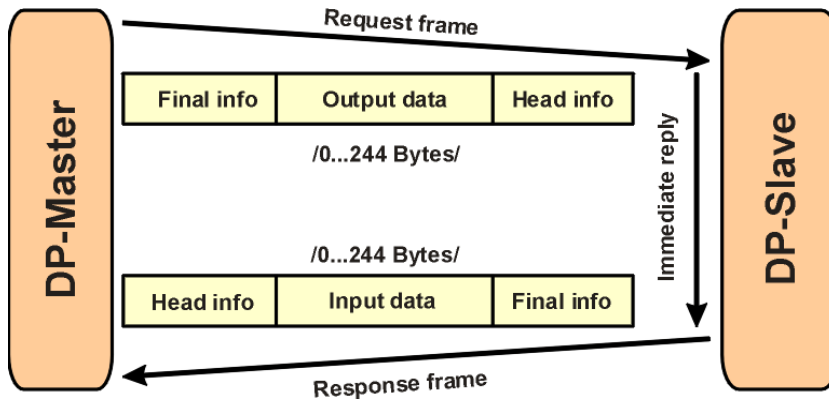

Figure 3 Cyclic User Data Transmission in DP

The data communication between the DPM1 and the slaves is divided into three phases: parameterization, configuration and data transfer. Before the master includes a DP slave in the data transfer phase, a check is run during the parameterization and configuration phase to ensure that the configured set point configuration matches the actual device configuration. During this check, the device type, format and length information and the number of inputs and outputs must also correspond. This provides you with reliable protection against parameterization errors

2.3.2 Diagnostic

In addition to the cyclic data the PROFIBUS slave unit provides diagnostic data. With this diagnostic data the slave can indicate errors or warnings on the slave unit, the I/O-units or the I/O-channels. Some diagnostic data is generic and defined by the PNO. But most of the diagnostic data is manufacturer specific.

An example for generic diagnosis is: Slave not ready, Parameter fault and Watchdog monitoring.



Digital Gateway supports only generic diagnostic. Extended (manufacturer specific) diagnostic is not used.

2.3.3 Sync and Freeze Mode

In addition to the normal cyclic communication between the DPM1 (DP Master Class 1) and the assigned slaves, a master can send the control commands sync and freeze via multicast to a group of slaves.

With the sync-command the addressed slaves will freeze the outputs in their current state. New output values received by the master will be stored while the output states remain unchanged. The stored output data are not sent to the outputs until the next sync command is received. The Sync mode is terminated with the “unsync” command.

In the same way, a freeze command causes the addressed slaves to enter freeze mode. In this mode, the states of the inputs are frozen at their current value. The input data are not updated again until the master sends the next freeze command. Freeze mode is terminated with the “unfreeze” command



Digital Gateway does not support Sync Mode and Freeze Mode even if it is selectable in GSD configuration.

2.3.4 DP Master Class 1 (DPM1) and Class 2 (DPM2)

The DP master class 1 is the master that is in cyclic data transmission with the assigned slaves. To get into the cyclic communication the DPM1 has to configure the slave before.

The DP master class 2 is used for engineering and configuration. It does not have cyclic data transmission with the slave devices. Normally a DPM2 is only connected temporarily to the bus. A DPM2 can have class 2 communication to the slave devices before the slaves are configured via DPM1 and cyclic communication is active.



Digital Gateway supports communication with DPM1 only.

2.3.5 Monitoring the DP-V0 Communication

The cyclic communication between the DPM1 and the slaves is monitored by the master and the slaves itself. If the DPM master unit detects a failure in the communication with a slave, it will indicate the corresponding slave as disturbed.

On slave side the communication with the master is controlled via the watchdog. If no data communication with the master occurs within the watchdog control interval, the slave automatically switches its outputs to the fail-safe state.



PROFIBUS watchdog must be enabled for master and failsafe functionality must be parameterized for Digital Gateway.

2.4 PROFIBUS DP-V1

2.4.1 Acyclic Data Communication

The key feature of version DP-V1 is the extended function for acyclic data communication. The acyclic data communication is mainly used for configuration and parameterization purpose. With the acyclic DP-V1 read and write services the master can read or write any desired data to and from the slave. The data is addressed by slot, index and length. Each data block can be up to 240 bytes.

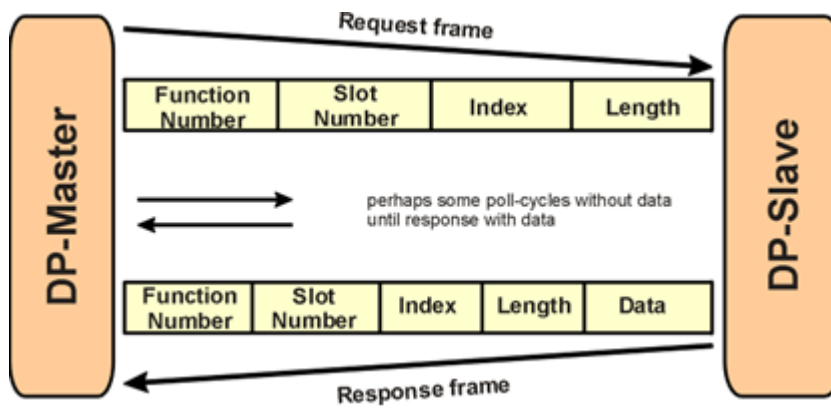

Figure 4 Acyclic Communication in DP-V1: Read Service

The transmission of acyclic data is executed in parallel to the cyclic data communication, but with lower priority. Acyclic services are operated in the remaining time at the end of the DP-V0 cycle.

3. Interfaces

3.1 Front View

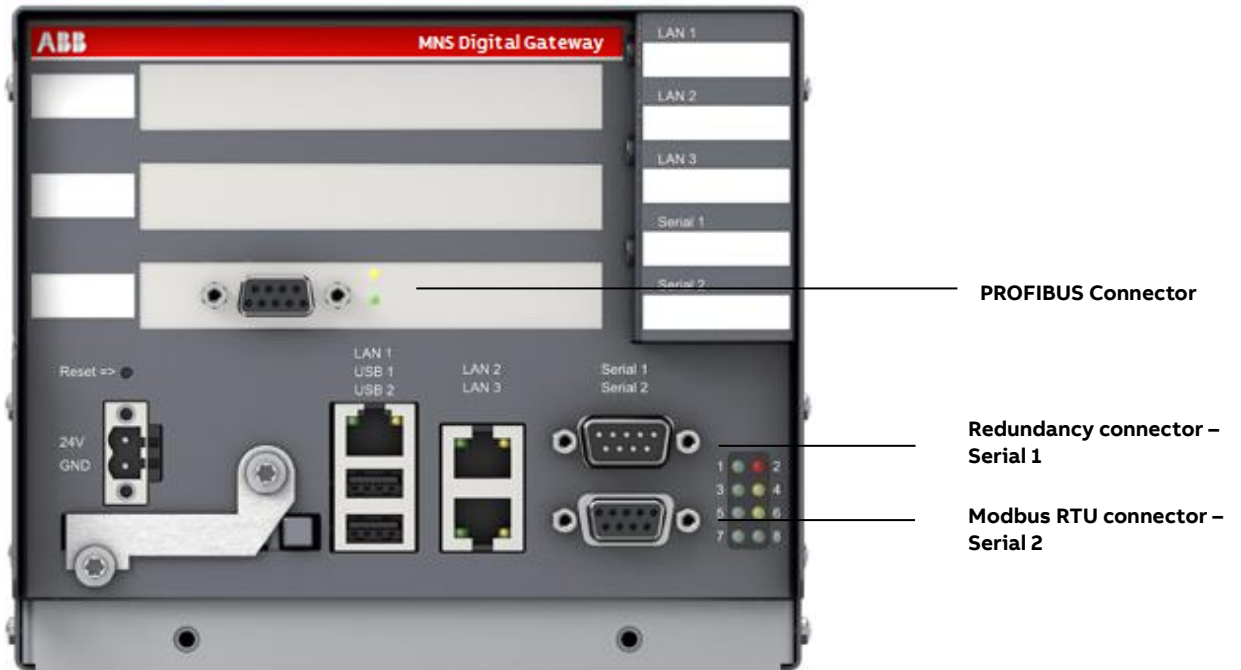

Figure 5 Digital Gateway front view

PROFIBUS DP	
PROFIBUS – upper LED, yellow	PROFIBUS Communication running
PROFIBUS – lower LED, yellow	PROFIBUS READY for communication
POWER SUPPLY	
Button Reset	Reset button (Restart of Digital Gateway)
24V	Power Supply +24VDC
GND	Power Supply 0V
CF CARD	
CF Card	CF card is protected against unintentional removal after closing the flap and connecting the power supply
PORTS	
LAN 1	LAN 1 Interface (Modbus TCP)
LAN 1 – LED left, green	Link LAN 1 active

LAN 1 – LED right, yellow	Communication Ethernet LAN 1
LAN 2	LAN 2 Interface (Switchgear Control Network)
LAN 2 – LED left, green	Link LAN 2 active
LAN 2 – LED right, yellow	Communication Ethernet LAN 2
LAN 3	LAN 3 Interface (Not used)
LAN 3 – LED left, green	Link LAN 3 active
LAN 3 – LED right, yellow	Communication Ethernet LAN 3
USB 1, 2	Not used
Serial 1	Redundancy Interface (male plug)
Serial 2	Modbus RTU Interface (female plug)
LED INDICATIONS	
LED 1	Digital Gateway Run indication (CF card application loaded and running)
LED 2	Digital Gateway Fault
LED 3	Application dependent (see section LED indication, page 60)
LED 4	Application dependent (see section LED indication, page 60)
LED 5	Application dependent (see section LED indication, page 60)
LED 6	DCS Communication active
LED 7	Digital Gateway Power On Indication
LED 8	Application dependent (see section LED indication, page 60) In redundant configurations: Digital Gateway primary

Table 3 Front View Connectors, LED and Push Buttons

3.2 Power Supply

The Digital Gateway requires 24V DC supply voltage. The connection is on the left side of the device with terminal plugs:

- Terminal 1 connects to +24V DC
- Terminal 2 connects to 0V DC

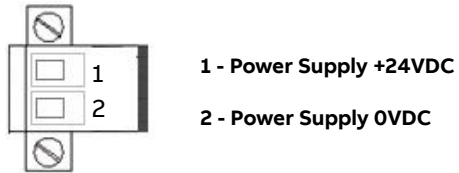

Figure 6 Power Supply Connector

4. Digital Gateway Installation

4.1 Digital Gateway Mounting

The Digital Gateway is installed inside the switchgear on a Digital Gateway mounting kit (part ID: 1TNA704001R0003) which is housed in an 8E withdrawable module compartment of the MNS cubicle. The Digital Gateway mounting kit is capable to support mounting for up to three Digital Gateway.

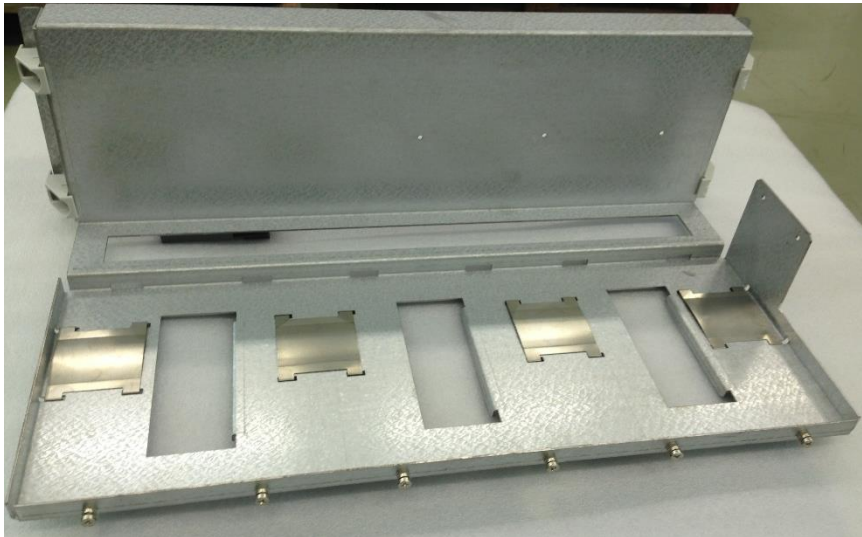

Figure 7 Digital Gateway Mounting Kit

4.2 CF Card Installation

The Compact Flash (CF) card is required to start and run the Digital Gateway. The procedure to create the CF card configuration and copy all mandatory files is described in the MNavigate help file.



Only Industrial Grade CF cards shall be utilized to ensure correct function of the Digital Gateway in the switchgear environment!

The CF card slot is located on the Digital Gateway front side. To remove or insert the CF card the power supply connector must be removed, and the metal cover has to be lifted. This ensures that CF card can only be removed/inserted while power supply is off.

CF card shall be inserted with the correct side up and with care as the card is mechanically coded and insertion should not be forced.

The following example shows the ABB standard CF card.



Figure 8 CF Card Insertion



Figure 9 CF Card Insertion Detail

5. Communication Interface Connection

5.1. Switchgear Bus Network

The communication between Digital Gateway and UMC is established via Modbus TCP protocol.

The hardware interface between Digital Gateway and UMC requires an Ethernet adapter module (MTQ 22 FBP) to convert signals from UMC FBP to Modbus TCP. Ethernet cable needs to be connected between Digital Gateway LAN3 port and either port E1/E2 of the MTQ 22. One MTQ 22 can support up to 4 UMC devices.

The 2 Ethernet ports on MTQ22 act as integrated switch, thus increasing the flexibility in configuration. The figure below shows possible Ethernet topology connections to the MNS Digital Gateway.

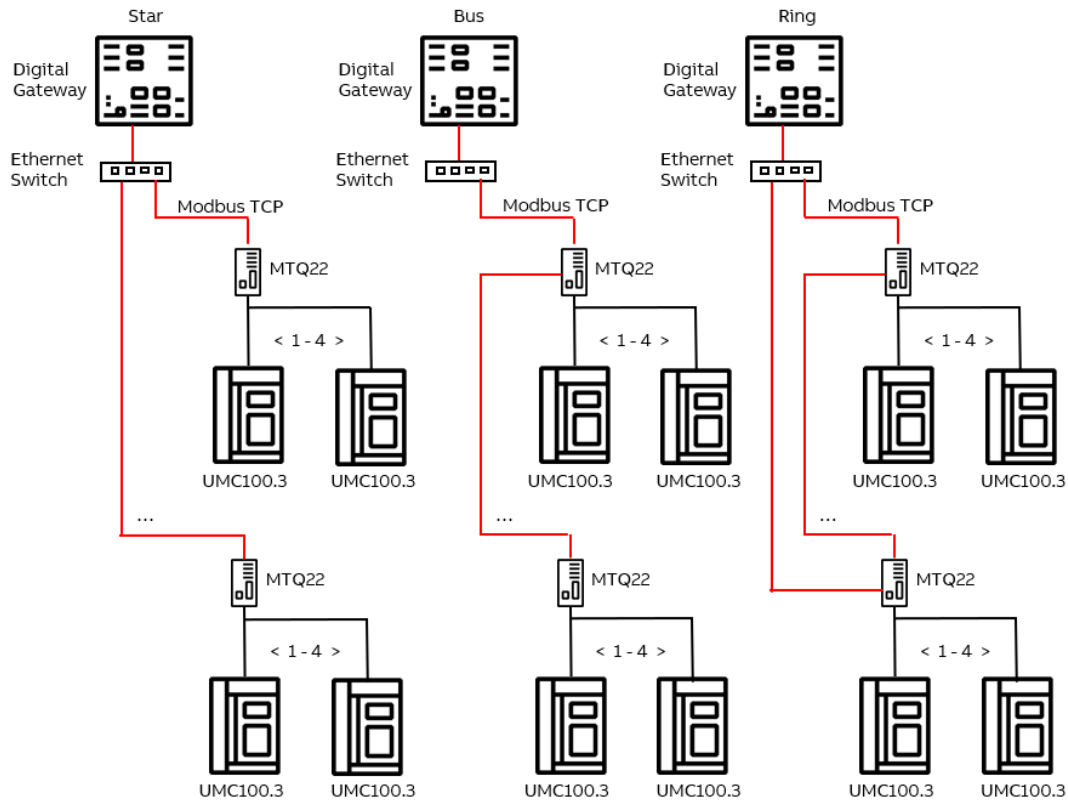

Figure 10 Different hardware connections possible between Digital Gateway and MTQ22



The ring topology offers cable redundancy on Ethernet side. This topology requires a managed switch which supports MRP (Media Redundancy Protocol). The redundancy protocol implemented in the MTQ22-FBP is according to EN/IEC 62439-2.

Before any Ethernet communication can be established, it is required for every MTQ22-FBP to have a unique IP address.

The internal switchgear network (FBP) connects UMC and MTQ22-FBP via a prefabricated field bus plug communication cable. Each of the UMC devices need its address to be configured, in accordance to the port number connection in the MTQ22-FBP.

For further details about MTQ22-FBP, refer the following document “2CDC194003D0202 Technical Description FBP Fieldbus Plug MTQ-22FBP”.

5.2 Switchgear Control Network

Digital Gateway can be connected to a standard 10/100/1000 Base-T Ethernet network through **LAN2** interface (Switchgear Control Network). Network components are standard (COTS – commercial of the shelf) components but shall be of industrial grade design (e.g. no office switches shall be used).

Examples of connections are shown in the following figures. All System configuration tools (e.g. MNavigate) and system components (LVS Digital Edge Gateway, Time Server) are connected to this network (see Figure 2). The cable shall be CAT5 / CAT6 depending on requirements based on the selected Ethernet communication speed. The connector type is standard RJ45 type.



If the switchgear control network has any connection to other networks (e.g. plant management network etc.) measures must be taken to protect the switchgear control network against unauthorized access (e.g. through Router and Firewall). This is a project specific configuration. Contact always the local network administrator and review the project specific requirements.



If managed switches or routers are used in the Ethernet network, it has to be taken care that sent ARP messages can pass through. Background: After reboot, Digital Gateway will send an ARP (Address Resolution Protocol) message to force all connected Ethernet devices to update their internal ARP table. This special ARP message is used to map the network layer address (MAC address) to a dedicated link layer address (IP address). This ARP table refresh is required to be able to establish an Ethernet communication.

5.2.1 Connection Examples of Switchgear Control Network

5.2.1.1 Option 1

If the Digital Gateway is directly connected to CMES Edge a cross-over network cable is used. On the Digital Gateway, the cable must be connected to the LAN2 Ethernet port, on CMES Edge the cable must be connected to the designated Ethernet connector. The cable type is CAT5 or higher.

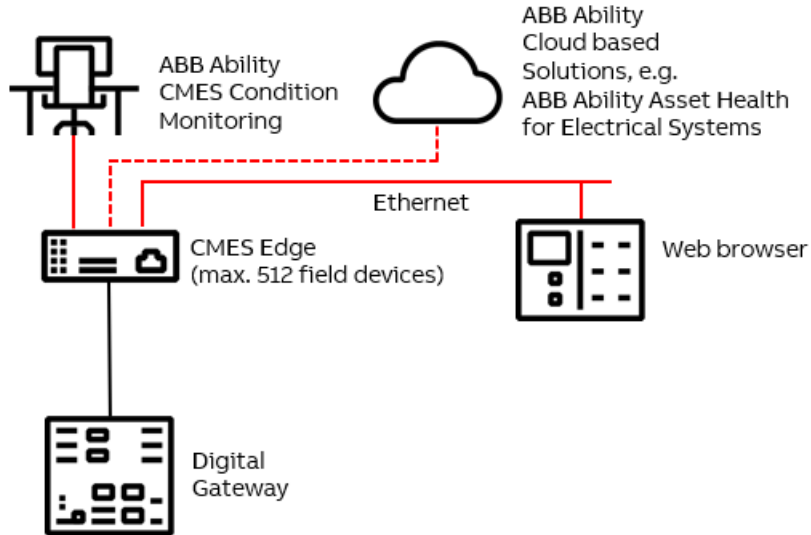

Figure 11 Digital Gateway directly connected to LVS Digital Edge Gateway

5.2.1.2 Option 2

Digital Gateway connected to Switchgear Control Network providing facility to connect additional Digital Gateway and other system tools and components (e.g. LVS Digital Edge Gateway, Web browser, Time Server, configuration tool, etc.). A network switch has to be installed in the plant. All network components are connected to the switch with standard CAT5 / CAT6 patch cable.

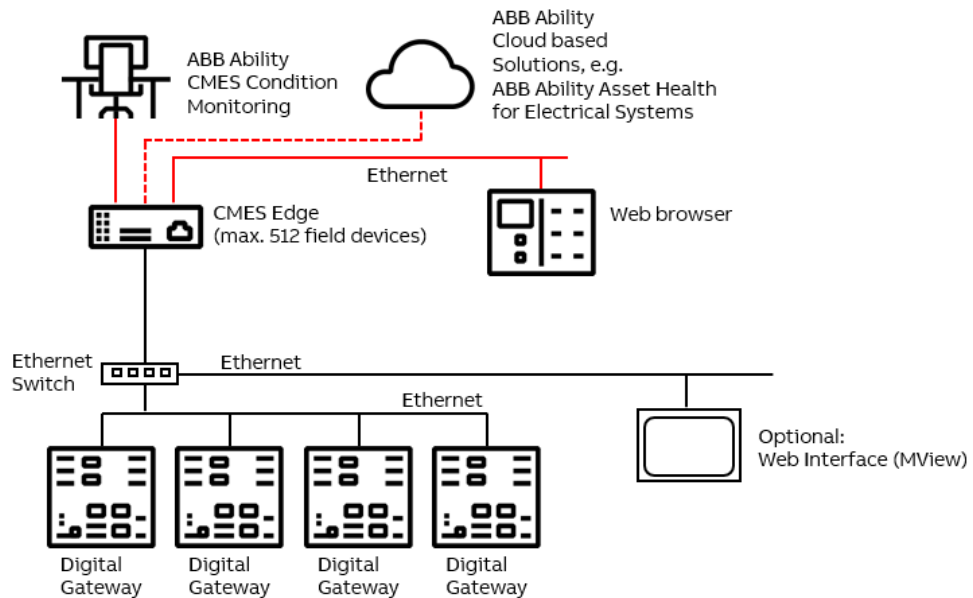

Figure 12 Network connection of Digital Gateway and LVS Digital Edge Gateway.



It is recommended that a managed network switch is used to connect the Digital Gateway to the PCS or PLC. The switch is not part of the MNS assembly but may be delivered together with the switchboard depending on project scope definition.



To ensure proper system performance following design rules shall be obeyed:

- Not more than 2 MView (optional) shall be connect to one Digital Gateway at the same time.
- If many Digital Gateway are connected to the same network, then network performance slows down. In such a case the network shall be split into different LAN segments (e.g. VLANs – can be configured in managed switches).

5.3 Time Synchronization

In order to provide the correct time and date the Time Sync option must be activated in Digital Gateway and it may require a time server in the Switchgear Control Network.

The protocol used for time synchronization is the standard Network Time Protocol (NTP).

i Time Sync must be activated through the ABB Engineering Tool.

5.3.1 Option 1

A standard network component is installed which can provide the time signal as NTP Server. Such a NTP Server can be a computer or network server as well as Ethernet switches. As an option, this NTP Server can be equipped with a GPS Receiver to provide accurate time for the location.

i In case of Option 1, Time Server hardware is not part of MNS and has to be supplied separately.

! If the Time Server is out of service, the Digital Gateway runs with the internal RTC (Real Time Clock) until a new Time Server signal is available. Redundant Time Servers are not supported.

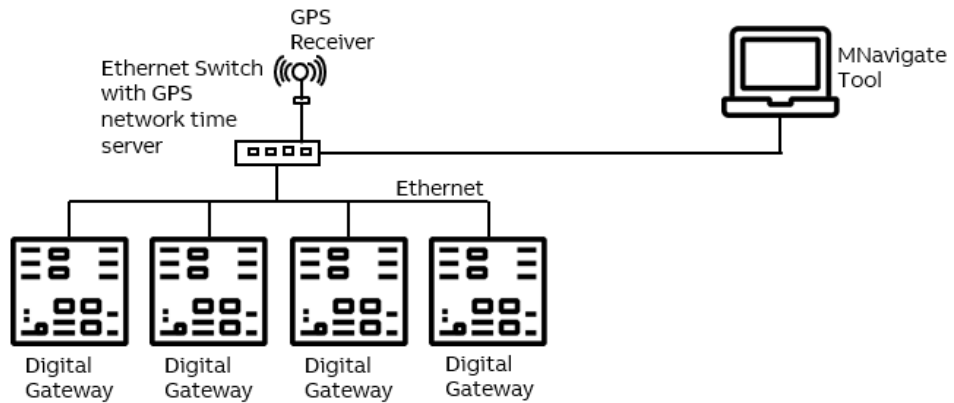

Figure 13 Example, showing 3rd party Network Switch and 3rd party NTP Server in a Switchgear Control Network

5.3.2 Option 2

One Digital Gateway in the network is configured as NTP Server (Time Sync mode = RTC). In this case the date and time for this Digital Gateway must be set through the web interface. All other Digital Gateway are configured as NTP Client (Time Sync mode = NTP) and their internal clock is synchronized by the NTP Server Digital Gateway.



In case of a power down the Digital Gateway buffers the system time (RTC) for about 3 hours. Afterwards its internal clock is reset to 2009-01-01.

This time synchronization method is less accurate than Option 1 since one Digital Gateway internal clock is used as time reference and not a high accurate GPS synchronized Time Server.

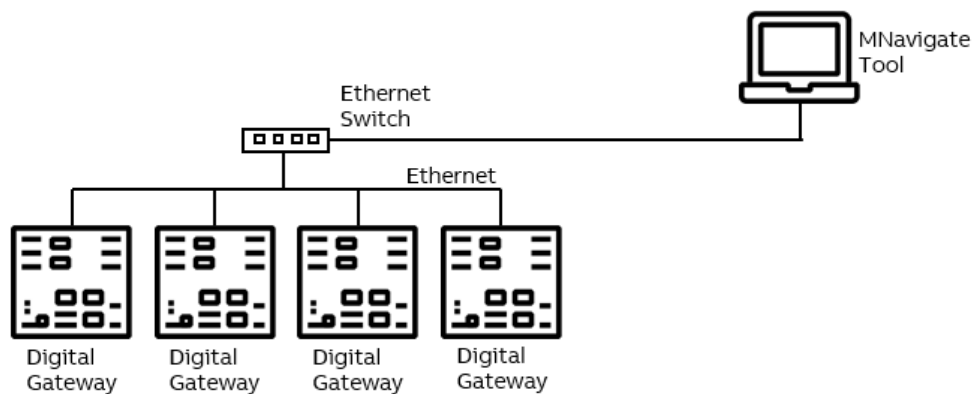

Figure 14 Example, using Digital Gateway as NTP Server

5.4 Fieldbus

5.4.1 PROFIBUS

The physical medium for PROFIBUS-DP is RS-485, which allows 32 nodes in a single segment and 125 nodes in a network using 4 segments. Segments must be separated by using Repeater.

The PROFIBUS interface checks input signal for poll requests from master and detects automatically requested baud rate. It can work with baud rates up to 1.5M.

Cable length may vary from 80-1200 m depending on transmission speed and repeater type in use. Cable length can be extended using fiber optic modems (yielding a more robust network). See reference document 4 for more details on cable connections and wiring.

The connection to the Digital Gateway is achieved via a PROFIBUS Standard Sub-D connector. In all PROFIBUS networks care must be taken that each end of a segment is terminated correctly termination must be activated. The Digital Gateway does not provide PROFIBUS Termination, the recommended method of termination is to utilize the termination switches of the standard D-types.

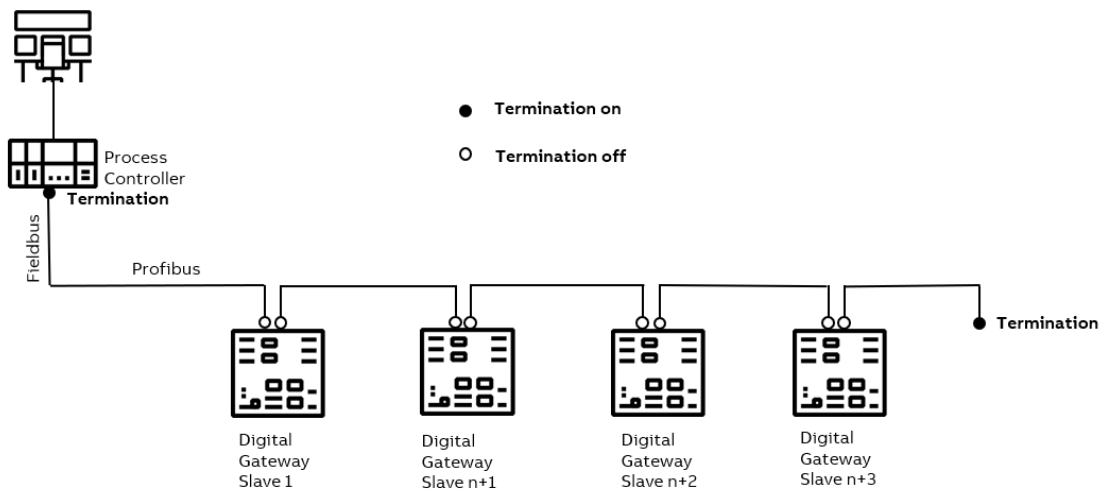



Figure 15 Digital Gateway PROFIBUS connection and termination examples

- 

In a mixed network, the maximum cable length of drop lines must be considered, also the max communication speed is less than 1.5 MBaud. See reference documents 1 & 3 for more information
- 

It is recommended to use external PROFIBUS termination devices. However, if that is not possible then standard plugs with inbuilt Termination shall be used. The Termination must be switched ON at both end of the segment. All terminations in between must be switched OFF



For LVS Digital Upgrade solution for INSUM 2, maximum 48 UMC devices can be connected to a Digital Gateway.

General PROFIBUS network information:

Baud Rate	Maximum Segment Length
9.6 kbit/s	1000m
19.2 kbit/s	1000m
45.4 kbit/s	1000m
93.75 kbit/s	1000m
187.5 kbit/s	1000m
500.0 kbit/s	400m
1.5 Mbit/s	200m
3.0 Mbit/s	100m
6.0 Mbit/s	100m
12.0 Mbit/s	100m

Table 4 Maximum segment cable length for RS485

Baud Rate	Total allowable stub capacitance	Total stub cable length*	Remarks
>1.5 Mbit/s	None	None	
1.5 Mbit/s	0.2 nF	6.7 m	Default baud rate INSUM PROFIBUS
500.0 kbit/s	0.6 nF	20 m	
187.5 kbit/s	1.0 nF	33 m	
93.75 kbit/s	3.0 nF	100 m	
19.2 kbit/s	15 nF	500 m	

*calculated for PROFIBUS cable type A at 30pf/m

Table 5 Maximum stub length for RS485

6.Redundancy

6.1 Redundant Architecture

A redundant system requires two Digital Gateway connected to the same internal switchgear bus. One Digital Gateway acts as Primary and the other acts as a Backup.

The primary Digital Gateway polls the UMC via internal Modbus TCP and is responsible for sending the switching commands, as well as reading the information fed back from the UMC via the Digital Gateway.

The Backup Digital Gateway reads the information only and is inhibited from sending switching commands.

The Primary and Backup Digital Gateway is synchronized using a redundant link cable.

A redundant system does can cover single system failures. Following theoretical failure situations are covered by a redundant system configuration:

On an active communication link:

- Failure in a PLC Fieldbus master or failure in a Fieldbus cable connection between one master and slave.
- Failure in a Digital Gateway *or* failure at the switchgear bus connection to a single Digital Gateway.

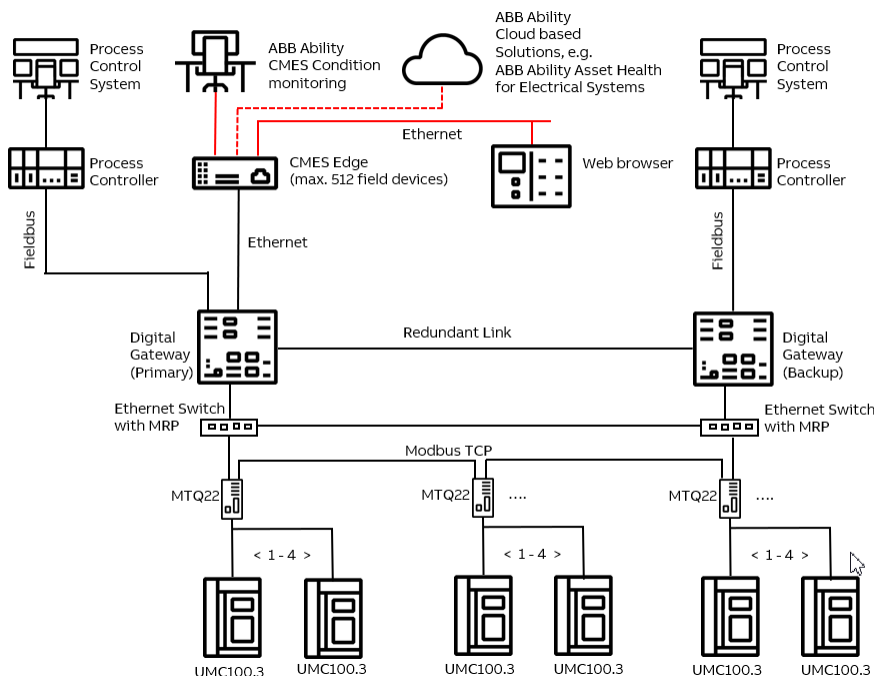

Figure 16 Redundancy configuration and possible failure scenario

If a failure is detected, from one of the 2 cases detailed above an integrated system mechanism ensures a bump less changeover from the ‘Primary’ Digital Gateway to the ‘Backup’ Digital Gateway. All process data, alarms and events and the system status information are then

available from the Backup Digital Gateway which will become the Primary Digital Gateway after the switch over.

To ensure the highest availability of the communication between Digital Gateway and UMC a ring topology is recommended.

To create an Ethernet Ring topology the switches used must support MRP (Media Redundancy Protocol). The MRP protocol implemented in the MTQ22-FBP is according to EN/IEC 62439-2.

6.2 Redundancy Configuration

There are three options available to connect DCS or PLC to both Digital Gateway

- One DCS / PLC Master connected to both Digital Gateway.
- One DCS / PLC with at least redundant (two) master interfaces
- Redundant (two) DCS / PLC Master where each is connected to one Digital Gateway (see example Figure 21)

6.2.1 Redundant Digital Gateway connection

Both Digital Gateway must be connected via a RS232 Null Modem cable (port Serial 1 on both Digital Gateway) to enable data synchronization and ensure correct operation



Figure 17 Serial 1 to serial 1 redundant link connections with ferrite core



The length of this cable should not exceed 10 meters

Redundant Link Cables		2m	1TGE120109R0002
		3m	1TGE120109R0003
		5m	1TGE120109R0005
		10 m	1TGE120109R0010
Ferrite Core			1TGB000197P0001

Table 6 Serial Redundant Link Cable ordering code

6.2.2 Digital Gateway Redundant Configuration

Configuration and Parameterization of LVS Digital [Upgrade] projects are done via MNavigate tool.

The parameters must then be downloaded to both the Primary and Backup Digital Gateway to become effective.

In a project with multiple Digital Gateway most of the Digital Gateway parameter are identical. To ease the parameterization such parameters could be copied among the Digital Gateway (Assign to Digital Gateway).

As Network address settings are different between the Digital Gateways if connected to the same network those must be configured individually

The steps of configuring the redundant Digital Gateway is as following:

1. Set the Ethernet IP address of LAN1 and LAN2 for Primary and Backup LVS Digital Gateway.

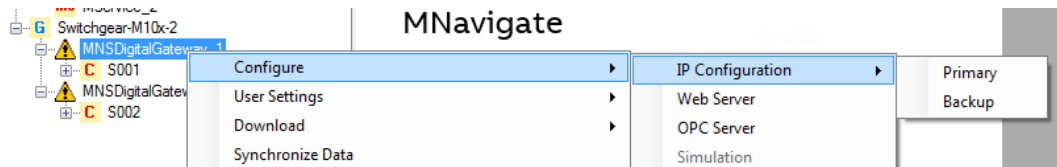

Figure 18 MNavigate IP address Parameterization for Primary and Backup Digital Gateway

Configuration Item	Primary Gateway (S001)	Backup Gateway (S002)
IP Address LAN2	192 . 168 . 200 . 100	192 . 168 . 200 . 101
Subnet Mask LAN2	255 . 255 . 255 . 0	255 . 255 . 255 . 0
Broadcast Address LAN2	192 . 168 . 200 . 255	192 . 168 . 200 . 255
Default Gateway LAN2	0 . 0 . 0 . 0	0 . 0 . 0 . 0
IP Address LAN1	192 . 168 . 100 . 100	192 . 168 . 100 . 101
Subnet Mask LAN1	255 . 255 . 255 . 0	255 . 255 . 255 . 0
Broadcast Address LAN1	192 . 168 . 100 . 255	192 . 168 . 100 . 255
Default Gateway LAN1	0 . 0 . 0 . 0	0 . 0 . 0 . 0
IP Address LAN3	192 . 168 . 171 . 100	192 . 168 . 171 . 101
Subnet Mask LAN3	255 . 255 . 255 . 0	255 . 255 . 255 . 0
Broadcast Address LAN3	192 . 168 . 171 . 255	192 . 168 . 171 . 255
Default Gateway LAN3	192 . 168 . 171 . 1	192 . 168 . 171 . 1

Network addresses must be set for both Primary and Backup Digital Gateway.

Table 7 Primary and Backup IP address setting



- It is essential that the IP address setting for LAN 2 of Primary and Backup Digital Gateway is different (e.g. Primary = 192.168.200.100 / Backup = 192.168.200.101).
- The same subnet mask is used because both Ethernet ports are connected to the same Ethernet network for MView and MNavigate communication.

2. Set the slave address for the selected Fieldbus / Field network interface.

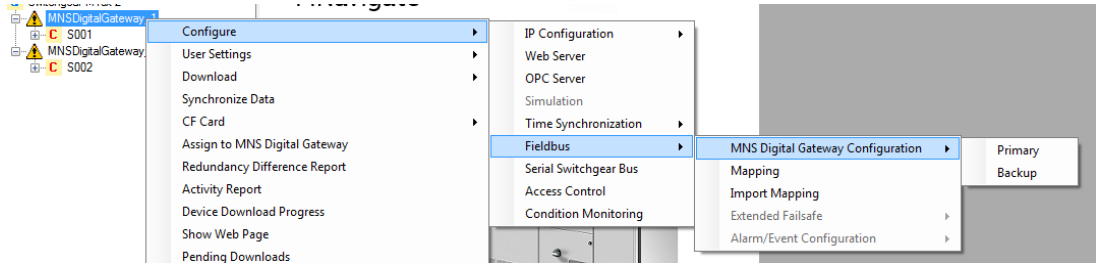

Figure 19 MNavigator Fieldbus Slave address Parameterization for Primary and Backup Digital Gateway

6.3 Handling of redundancy faults

Both Digital Gateway always supervise the redundancy conditions, detecting faults and problems according following table:

Event	Action
PLC or DCS connection interrupted for more than 1 second to Primary Digital Gateway	Redundancy change over if backup Digital Gateway has an active PLC or DCS connec-
Power loss or internal error of Primary Digital Gateway	Redundancy change over, Redundancy error indi-
Power loss of backup Digital Gateway	No change over, Redundancy error indicated
Problems in redundancy setup	No change over possible, Redundancy error indi-
Switchgear Bus at Primary Digital Gateway disconnected	Redundancy change over

Table 8 Primary and Backup IP address setting



A change over from Primary to Backup Digital Gateway will only be performed if there is no redundancy error.

Nevertheless, it is also possible that the DCS/PLC initiates a change over by sending respective change over command. It needs to be ensured that the switch over commands are configured in Digital Gateway mapping for the respective fieldbus.

6.4 MView / Web Interface

In a dual redundant configuration, the MView is connected via the same Ethernet network to both Primary and Backup Digital Gateway.

If a changeover takes place, the current Primary will become the Backup (if still functioning) and the Backup will become Primary Digital Gateway.

The MView is automatically redirected to the new Primary Digital Gateway (which was the Backup Digital Gateway before) without user interaction.

While redirecting, the MView shows the following window: Prior to the re-direction the background in MView changes to yellow to indicate that current Web Interface is connected to the Backup Digital Gateway. Once it has re-directed to the new Primary Digital Gateway the background returns to its usual color.

Below screenshots are showing such a change-over scenario:



Figure 20 MView Redirecting to Redundant Digital Gateway



Figure 21 Redundancy error shown in MView by a red square

Note: If a change-over fails or in case any other redundancy error occurs that will be indicated by red square in MView (see Fig26 above).

7. Configurations

7.1 Initial Values – IP Configuration

Digital Gateway requires parameter settings as initial values for network operation. The parameters are required depending on Digital Gateway configuration. Additionally, parameter for Web Server, OPC Server and Fieldbus are also required.

The parameters must be loaded onto the Compact Flash (CF) card using MNavigate tool before powering up. After successful communication between MNavigate and LVS Digital Gateway (either direct or via network) the parameters can then be changed from MNavigate through the network.



Any change of communication related parameter for Ethernet network (e.g. IP address) requires a restart of Digital Gateway. Fieldbus communication related parameter (e.g. comm. speed, or slave address) can be change during runtime of Digital Gateway.

Parameter	Default Value	Range	Remarks
IP Address LAN 2 (LAN2)	192.168.200.100		Settings according to network administrator
Subnet Mask LAN2	255.255.255.0		Settings according to network administrator
Broadcast Address LAN2	192.168.200.255		Calculated automatically
Default Gateway LAN2	0.0.0.0		Settings according to network administrator
IP Address LAN 1 (LAN1)	192.168.100.100		Settings according to network administrator
Subnet Mask LAN1	255.255.255.0		Settings according to network administrator
Broadcast Address LAN1	192.168.200.255		Calculated automatically
Default Gateway LAN1	0.0.0.0		Settings according to network administrator
IP Address LAN 3 (LAN3)	192.168.171.100		Settings according to MTQ22 FBP addressing
Subnet Mask LAN3	255.255.255.0		Settings according to MTQ22 FBP addressing
Broadcast Address LAN3	192.168.171.255		Calculated automatically

Default Gateway LAN3	192.168.171.1	Settings according to MTQ22 FBP addressing	
Time Synchronization	RTC	RTC, NTP	RTC=internal clock, NTP=if external NTP server is available
Time Server Address	0.0.0.0	Settings according to network administrator	

Table 9 Digital Gateway Default Parameters – IP Configuration

7.2 Settings – IP Configuration

All configuration settings and parameterization for the Digital Gateway are configured with the MNavigator software tool.

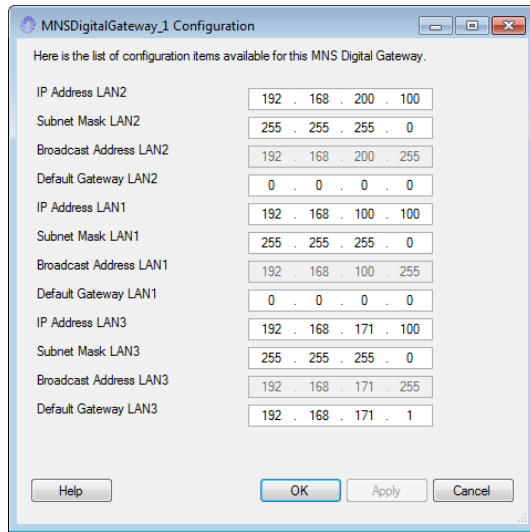

Figure 22 IP Address Settings

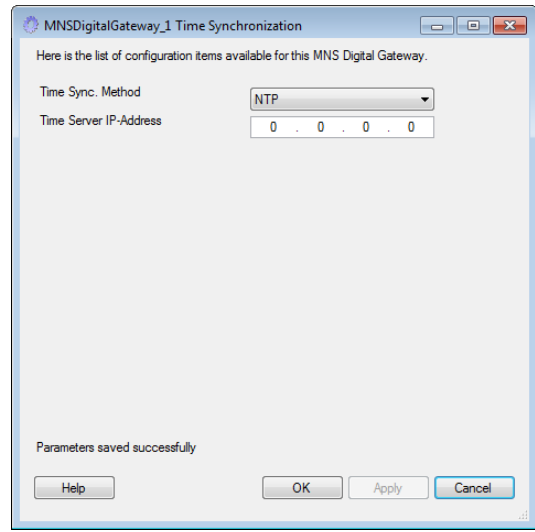

Figure 23 Time Sync Settings



Digital Gateway does not support DHCP service to get automatic network address. If the default IP Address and Subnet Mask must be manually adjusted, the parameter above must be modified and copied to the Digital Gateway. Any change in the address requires the Digital Gateway to be restarted before the change is activated.



It must be ensured that the Subnet address (**xxx.xxx.xxx.yyy**) for LAN1, LAN2 & LAN3 port are different. For example, LAN1 = **192.168.100.100** and LAN2 = **192.168.200.100**

7.2.1 Definition of IP Addresses

An IP Address is a required setting in order to allow data communication in an Ethernet network. If the devices are integrated in a plant network, the local network administrator must be consulted to find correct settings.

The Subnet Mask defines the size of the network. In typical applications the subnet mask is as per default settings. However, the local network administrator must be consulted, if other IP addresses than the default settings apply.

The Broadcast Address is required for the Digital Gateway to send data to other devices. Since the Digital Gateway does not know which IP address is used by the other devices, data is sent as broadcast messages. The broadcast address is calculated automatically by MNavigate.

The Default Gateway is an address for a network gateway, if the switchgear control network is connected to a plant network. The gateway is not part of the MNS scope. If a gateway is used, the local network administrator is to be consulted for correct settings.



If it is not possible to communicate to the Digital Gateway, please refer to the trouble shooting section in this document or the Digital Gateway section in the MNavigate Help file

7.3 Settings – PROFIBUS Communication

Parameter	Default Value	Range	Remarks
PROFIBUS Slave Address	126	3...125	PROFIBUS station address
GSD Configuration	244 read – 124 write	244 read – 124 write 120 read – 60 write 32 read – 16 write INSUM 2 Gsd 165A INSUM 2 Gsd 067e	Selects the data length module definition from the GSD file. Only for LVS Digital Upgrade solution : Support of INSUM 2 GSD for INSUM 2 Upgrade solution
PLC Timeout Enable	No	Yes, No	Activates PLC Time Out parameter
PLC Timeout	10	1...120 seconds	Delay until Failsafe is activated

Table 10 Digital Gateway Default Parameters – PROFIBUS configuration

Configuration of the parameters is done via MNavigate. The parameters must then be downloaded to the Digital Gateway.

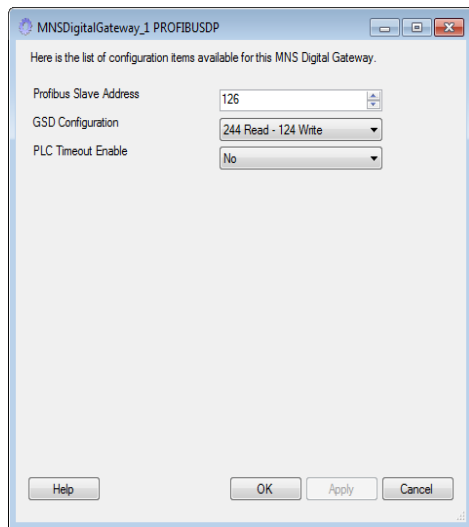

Figure 24 Parameter Window for PROFIBUSDP parameters in MNavigate

7.4 Addressing

PROFIBUS DP allows the address range of 0 to 127. Following reservations apply:

- 0, 1 - reserved; used for PROFIBUS Master
- 2 - reserved; PROFIBUS Digital Gateway address during re-boot only
- 126, 127 - reserved

Above reserved addresses must not be used for PROFIBUS Digital Gateway or any other slave device in the network. All other addresses are available for free use.

It must be ensured that the selected address is unique in a network connected to the PROFIBUS Master. Double addressing in the network will cause communication errors on PROFIBUS.



It is recommended to set the Highest Station Address (HSA) in the *PROFIBUS Master* to 125 to be able to add new Slave devices (which have default address of 126) without a disturbance of the PROFIBUS communication.



The Digital Gateway does not support address setting / editing from the PROFIBUS Master. The address must be defined with the LVS Digital parameter "PROFIBUS Slave Address".

If more than 32 devices are connected to a segment, repeater devices have to be used. Such repeater counts as one Slave within a segment without using an address number. Thus only 30 Slaves are possible within a segment.

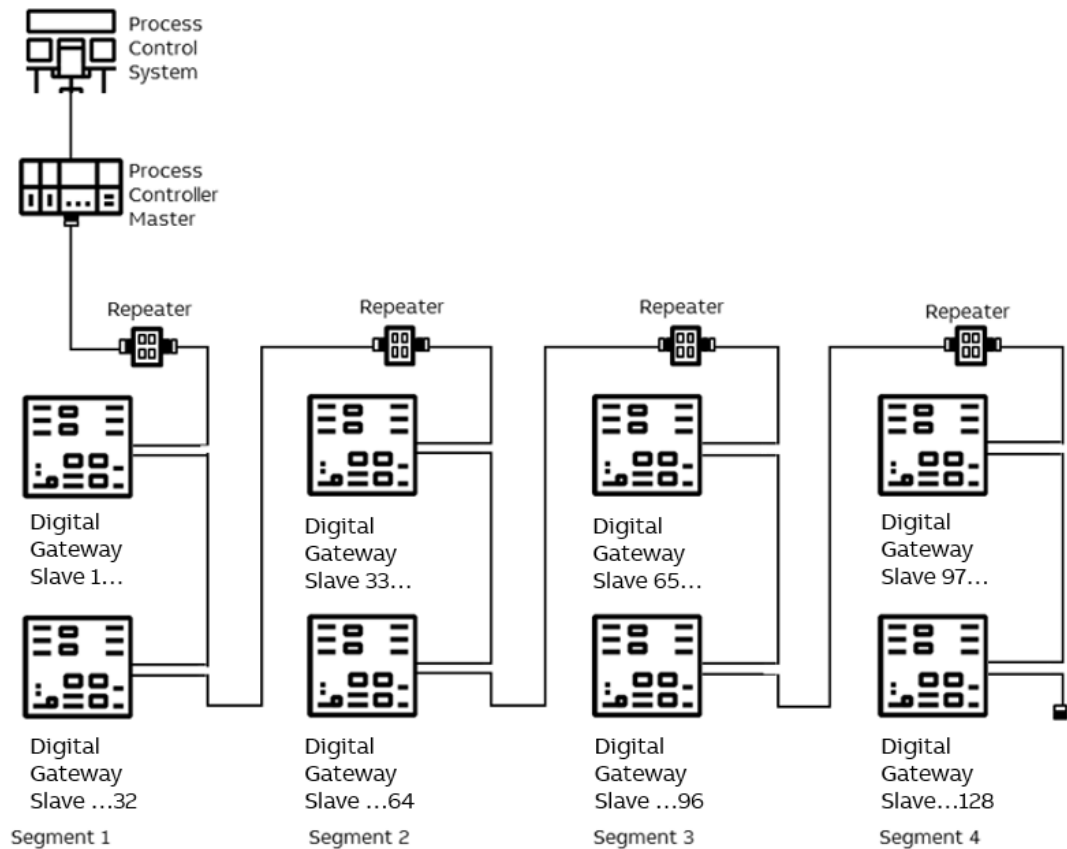

Figure 25 Example of max address range and slave numbers on one PROFIBUS Master

7.5 Failsafe

In circumstances where a disturbance in the MODBUS communication network needs to be monitored it is possible to select a 'Failsafe' state for each UMC. This state must be defined as a parameter for each UMC separately. The Digital Gateway supervises the MODBUS communication to the PCS or PLC if the parameter PLCTimeOut is set to "YES". The timeout for this connection is set by using the parameter PLCTimeOut (see Table 9 and 10 for initial values).



The UMC must be operating in 'Remote' mode for the Failsafe function to be active.

7.6 Start-up of Digital Gateway and application download

7.6.1 Power-On procedure



Before Power On, complete a visual check of power cable connection and overall wiring of the switchboard. The Digital Gateway requires parameter settings to function correctly. Parameter settings are completed with MNavigate. If Digital Gateway is configured with an optional single MView in a stand-alone configuration then the default settings can be applied. Otherwise the settings must be configured before start-up.



Any change of configuration settings on the Digital Gateway requires restart of the Digital Gateway. During Digital Gateway restart all communication on the switchgear bus network as well as communication to DCS/PLS/PLC is stopped. After reboot is completed all communications are re-established.

7.6.2 Power On the control voltage supply

The Digital Gateway boots automatically. At this time the Digital Gateway performs internal software checks and verifies that the data available on the CF card is correct.

At the end of boot sequence, the LED 7 & LED 1 (Run) should be on as a minimum.

7.6.3 Confirm operation

Once correct operation has been established it is then possible to proceed with system configuration and application download.

8. Data Mapping

Two possibilities exist for data mapping, the default data map as described below and a user defined data map which can be created by the MNavigate Mapping Tool for project specific tailoring of the communication data.

The default data map is a selection of data based on typical requirements. If this selection is not accepted in the project, a user data map has to be created.

8.1 User Data Map

All available data in a UMC can be assigned to the corresponding register addresses by using the MNavigate Mapping Tool. This is a proprietary tool for ABB to program the PROFIBUS registers according to customer requirements.



If there is a communication interruption between a UMC (e.g. device removed) and the related Digital Gateway, then the information configured in the mapping for this device will show the last values before the interruption.

At the same time the Life Bit for this device, which shall be always part of a User Mapping, is cleared to 0 (1 is indicating device is communicating).

This Life Bit information for each configured device shall be used in DCS to validate the Read-Data from the device. An Alarm shall be raised if Life Bit value becomes “0” to indicate that the communication to that single device is disturbed and no remote control of the connected motor/load is possible any longer.



For LVS Digital Upgrade projects only:

For INSUM 2 Upgrade solution with Profibus DP interface, a default Profibus mapping is available for the interface between Digital Gateway and DCS. This mapping follows the INSUM 2 Profibus Gateway default mapping.

8.2 Default Data Map

Through the default PROFIBUS data map 60 UMC data are provided. Process operation data are sent and received through cyclic DP communication, while the acyclic communication is used to send additional information for system status and maintenance.



If Profibus Default Mapping is configured and a communication interruption between a UMC (e.g. device removed) and the related Digital Gateway occurs then all information configured in the mapping for this device will be cleared to “0”.

At the same time the Life Bit for this device (always part of Default Mapping) is cleared to 0 (1 is indicating device is communicating).

This Life Bit information for each configured device shall be used in DCS to validate the Read-Data from the device. An Alarm shall be raised if Life Bit value becomes “0” to indicate that the communication to that single device is disturbed and no remote control of the connected motor/load is possible any longer.

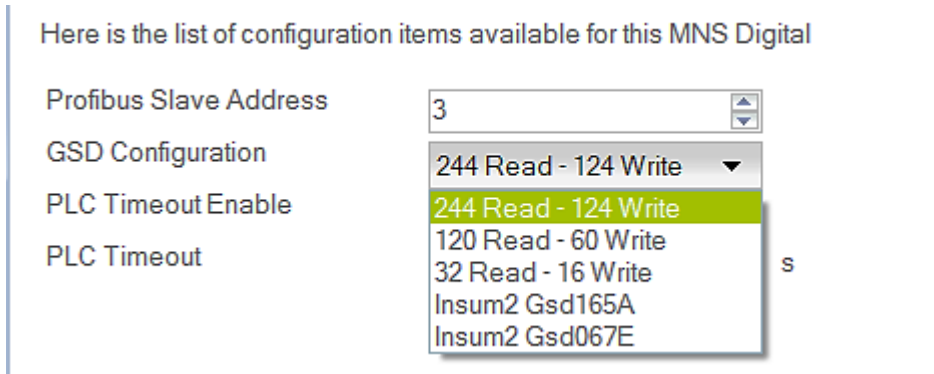

Figure 26 Mapping Selection from MNavigate

The dialog box highlights the options supported for the standard GSD Configuration. The default setting being 244 Read, 124 Write, the standard options are listed below.

- 244 Read - 124 Write enables communication with 60 UMC
- 120 Read - 60 Write
- 32 Read - 16 Write
- Insum2 Gsd165A (used only in LVS Digital Upgrade)
- Insum2 Gsd067E (used only in LVS Digital Upgrade)

8.2.1 Cyclic Data Communication (DP-V0)

8.2.1.1 Monitoring (Inputs from field device to master, class 1)

This section deals with the information that is read from the Digital Gateway by the PROFIBUS Master.

Byte	Monitoring data of
0..3	UMC 1
4..7	UMC 2
...	...
236..239	UMC 60
240..243	Reserved

Table 11 244 Byte Cyclic Data Structure

Byte	Bit 7	Bit 6	Bit 5	Bit 4	Bit 3	Bit 2	Bit 1	Bit 0
0	Trip new	Alarm	Remote	Reverse Lockout	TOL Alarm	Run CW	Off	Run CCW
1	Life bit	Ready	Test	GPI3	GPI2	GPI1		Run N2
2	Phase L1 Current Percent							
3	Phase L1 Current Percent							

Table 12 Monitoring Data Structure of a single UMC

8.2.2 Status Bit Explanation

Byte	Description		
Byte 0 Bit 7	Trip New	0 = no trip condition	1 = any trip condition of the available protection and supervision functions
Byte 0 Bit 6	Alarm	0 = no alarm	1 = any warning of the available protection and supervision functions
Byte 0 Bit 5	Remote	0 = not in Remote Control; any local control station (hardwired to I/O on UMC) is allowed to send control command	1 = Remote Control; the DCS or any control station on the switchgear control network is allowed to send control command
Byte 0 Bit 4	Reverse Lockout	0= Reverse lockout time is not active or has elapsed	1 = Reverse lockout time is active. Motor cannot start in reverse.
Byte 0 Bit 3	TOL alarm	0 = no Thermal Overload Warning (TOL) pending	1 = Thermal Overload Warning; set level for TOL is reached (i.e. 90%)
Byte 0 Bit 2	Run CW	0 = not running clockwise	1 = motor is running clockwise
Byte 0 Bit 1	Off	0 = motor is not stopped	1 = motor stopped or tripped
Byte 0 Bit 0	Run CCW	0 = not running counter clockwise	1 = motor is running counter clockwise
Byte 1 Bit 7	Life Bit	0 = UMC is not available (not communicating) Note: No Remote control of the motor/load possible !	1 = UMC is available (communicating)
Byte 1 Bit 6	Ready	0 = not ready to start	1 = ready to start = UMC connected & main switch on & no trip & no start inhibit
Byte 1 Bit 5	Test	0 = UMC not in test position	1 = UMC in test position; Main switch off but contactor control possible

Byte 1 Bit 4	GPI 3	0 = General Purpose Input 3 not active	1 = General Purpose Input 3 is active
Byte 1 Bit 3	GPI 2	0 = General Purpose Input 2 not active	1 = General Purpose Input 2 is active
Byte 1 Bit 2	GPI 1	0 = General Purpose Input 1 not active	1 = General Purpose Input 1 is active
Byte 1 Bit 1			
Byte 1 Bit 0	Run	0 = motor is not running	1 = motor is running

Table 13 Explanation of status bit

8.2.3 Commands (Output to field device from master)

This section deals with the commands that are sent from the Profibus Master to the MNS Digital Gateway.

Byte	Commands to
0..1	UMC 1
2..3	UMC 2
...	...
118..119	UMC 60
120..123	Reserved

Table 14 122 Byte cyclic Data Structure

Byte	Bit 7	Bit 6	Bit 5	Bit 4	Bit 3	Bit 2	Bit 1	Bit 0
0		Trip Reset all	Set CA to Remote			Start CW	Stop	Start CCW
1	GO01 Reset*	GO01 Set*	GO 00 Reset*	GO 00 Set*	Set CA to Bus Local			

- GO commands are only applicable when the UMC DO is programmed

Table 15 Command Data Structure of UMC

8.2.4 Command Bits Explanation

Byte	Description	
Byte 0 Bit 7	reserved	
Byte 0 Bit 6	Trip Reset	1 = to reset any trip condition
Byte 0 Bit 5	Set CA to Remote	1 = Instructs UMC to accept control commands from remote location (PLC / PCS)
Byte 0 Bit 4	reserved	
Byte 0 Bit 3	reserved	
Byte 0 Bit 2	Start CW	1 = UMC will start motor 'clockwise'
Byte 0 Bit 1	Off	1 = UMC will stop motor
Byte 0 Bit 0	Run CCW	1 = UMC will start motor 'counter clockwise'
Byte 1 Bit 7	GO01 Reset	1 = Reset 1DO1 of UMC (if parameter is set)
Byte 1 Bit 6	GO01 Set	1 = Set 1DO1 of UMC (if parameter is set)
Byte 1 Bit 5	GO00 Reset	1 = Reset 1DO0 of UMC (if parameter is set)
Byte 1 Bit 4	GO00 Set	1 = Set 1DO0 of UMC (if parameter is set)
Byte 1 Bit 3	Set CA to Bus Local	1 = Control Access is passed to any control station on the switchgear control network (MView or Web Browser)
Byte 1 Bit 2	reserved	
Byte 1 Bit 1	reserved	
Byte 1 Bit 0	reserved	

Table 16 Command Data Bits Explanation

8.2.5 Handling of Commands and Priority

Command priority

- If the Off bit is set Run Forward and Run Reverse are ineffective. Off command has highest priority.
- If Run Forward and Run Reverse are set, both commands are ineffective. No command is sent to UMC
- GPOx commands are sent with lower priority, they should not be used for time critical operations.

Command execution

- Only one command per received PROFIBUS telegram is accepted from UMC (either Run or Stop or Trip Reset)
- The Auto Mode bit must be set to one in order to execute commands via Fieldbus from a DCS/PLC.
- Commands are only executed if command bit has changed from 0 to 1.

User mapping command execution

- Command execution order for the Profibus user mapping is from lowest (bit 0) to highest bit (bit 7), this means bit 0 has the highest priority.

8.2.6 Redundant Digital Gateway Profibus Data

The following additional data mapping is provided for a redundant data interface to determine the status of Digital Gateway (Primary/Backup, Redundancy Error). It is also possible to send commands to force a change-over.

Byte	Bit 7	Bit 6	Bit 5	Bit 4	Bit 3	Bit 2	Bit 1	Bit 0
243							Redundancy Error	Primary

Bit 0 is set to indicate which Digital Gateway is currently set to Primary.

Bit 1 is set when there is a redundancy error, for example when 1 Digital Gateway is offline

Table 17 Redundant data for monitoring by the Profibus master

Byte	Bit 7	Bit 6	Bit 5	Bit 4	Bit 3	Bit 2	Bit 1	Bit 0
123								Redundancy Change Over

Bit 0 when this bit is sent to either the Primary or Backup Digital Gateway it initiates a change-over.

Table 18 Redundant Command possible from the Profibus Master



In case of a project specific mapping is used it is mandatory that above redundancy information is configured in the mapping of the respective fieldbus.

8.2.7 Control Access

Control Access (CA) is a mechanism within LVS Digital to define and determine which user interface has control rights to operate the UMC modules. These interfaces are defined below in command handling. Control Access rights can be given, for example, by a specific command sent to switch operation rights from push-button (hardwired to UMC) to any other interface connected via the Digital Gateway (e.g. MView or DCS).

8.2.7.1 Command Handling

The control access command defines the control rights of defined interfaces for an UMC.



Remote – UMC switches to Remote operation mode and can be operated via Fieldbus from process control system (DCS / PLC)



Bus-Local – UMC switches to the Bus-Local mode and operation is possible:

- via MView (local operation panel in switchboard) or
- via web interface (like MView).



Hardware-Local – UMC switches to the Hardware-Local mode and operation is possible only through digital inputs on UMC Hardware. Hardware-Local must be activated by the setting the input on the UMC.

	Command	Command	Status Bit
CA Interface	Auto Mode (CA Remote)	Bus Local (CA BusLocal)	Auto Mode (Bus Control)
DCS only	1	0	1
MView (Web interface)	0	1	1
Hardware Local (Hardware Inputs)	X	X	0

Table 19 Command and Status for Control Access

Notes:

At any time, any control station can obtain the control access by sending a control access command to UMC. On MView (or web interface) the user must have the appropriate user right to do so.

Hardware-Local must be activated by the setting the input on the UMC.

CA Remote is set if the command ‘Remote Control’ command is sent to the UMC from the DCS. Only then it is possible to send switching commands from the DCS.

CA BusLocal will be active if Auto Mode is not set and the Bus Local command bit goes from 0 to 1.

Hardware-Local overrides all other CA Levels. It is not possible for the DCS or MView to take control when the UMC is set to HW-Local.

Recommended procedure for sending control commands for a motor starter

1. Set the UMC to "Remote" with the command "Set CA to remote"
2. Set the desired state, "Run Reverse", "Off", "Run Forward" or "Trip Reset"
3. Wait until desired state is shown in motor state (received from Slave).
4. Reset previous command "Run Reverse", "Off", "Run Forward" or "Trip Reset"

8.2.8 Acyclic Data Communication (DP-V1 –master class 1)

The PROFIBUS DP-V1 function will provide additional asynchronous data transferred from each UMC. The data is listed in the tables below.

The DPV1 read request requires the following three parameters:

Slot number:

- UMC number (1... 60)

Index:

- Number of data set (see table below)

Length (defines data length):

- Range 1... 240

Maximum 56 byte of data can be read in one cycle. The starting point in the table is defined with the index number; the length can be between 1 to 56 bytes.

Example 1:

Slot number = 8; Index number = 0; Length = 38

From UMC 8 the following data is read:

“Current Phase L1 [A]” until “Apparent Power [VA]”

8.2.8.1 Default DP-V1 data

Index	Byte	Data Type	Description
Index 0	Byte 0 – Byte 3	ULONG_100	Current Phase L1 [A]
	Byte 4 – Byte 7	ULONG_100	Current Phase L2 [A]
	Byte 8 – Byte 11	ULONG_100	Current Phase L3 [A]
	Byte 12 – Byte 15	ULONG_100	Current [A]
	Byte 16 – Byte 17	UWORD	Current Percent [%]
	Byte 18 – Byte 19	UWORD	Current Unbalance [%]
	Byte 20 – Byte 21	UWORD	Current to Earth [%]
	Byte 22 – Byte 23	UWORD	Phase Voltage L1 – L2 [V]
	Byte 24 – Byte 25	UWORD	Phase Voltage L2 – L3 [V]
	Byte 26 – Byte 27	UWORD	Phase Voltage L3 – L1 [V]
	Byte 28 – Byte 29	UWORD_1000	Power Factor
	Byte 30 – Byte 33	ULONG	Active Power [Watt]

Byte 34 – Byte 37	ULONG	Apparent Power [VA]
Byte 38 – Byte 41	ULONG	Energy Used [kWh]
Byte 42 – Byte 43	UWORD_10	Frequency [Hz]
Byte 44 –Byte 45	UWORD	Max Current at Startup [%]
Byte 46 – Byte 47	UWORD	Thermal Image [%]
Byte 48 – Byte 49	UWORD	Time To Trip [s]
Byte 50 – Byte 51	UWORD	Time to Reset [s]
Byte 52 – Byte 53	UWORD	Operating Hours [h]
Byte 54 – Byte 55	UWORD	Number of Starts
Byte 56 – Byte 57	UWORD	Number of Emergency Starts
Byte 58 – Byte 61	ULONG	Status

Table 20 Default DP-V1 data

8.2.8.2 Status Byte Detail

BYTE	Description	Remark
Bit 0	Stopped	1 = Motor Stopped or Tripped
Bit 1	Runs	1 = Motor Runs
Bit 2	Runs CW/ Close	1 = Motor Runs, Clockwise
Bit 3	Runs CCW /Open	1 = Motor Runs, Counter Clockwise
Bit 4		
Bit 5	Actuator Close	1= Actuator at End Position Close
Bit 6	Actuator Open	1= Actuator at End Position Open
Bit 7	Ready	1 = UMC in correct location & main switch on & no trip & no start inhibit

Table 21 Extended Status Byte 58

BYTE 59	Description	Remark
Bit 0	Any Alarm	Set when any Alarm is present
Bit 1	New Trip	Set when any New Trip is present
Bit 2		Reserved
Bit 3		Reserved
Bit 4		Reserved
Bit 5		Reserved
Bit 6		Reserved
Bit 7		Reserved

Table 22 Extended Status Byte 59

BYTE 60	Description	Remark
Bit 0	Test Input	Isolator set to 'Test' position
Bit 1	Main Switch Input	Isolator set to 'On' position
Bit 2		Reserved
Bit 3		Reserved
Bit 4		Reserved
Bit 5	Start Inhibit	Set when start is inhibited
Bit 6	TOL Start Inhibit	Set when start is inhibited by TOL protection
Bit 7		Reserved

Table 23 Extended Status Byte 60

BYTE 61	Description	Remark
Bit 0	HW -Local	UMC accepts control commands from the hardwired inputs on UMC, when the respective Local control input is set to true.
Bit 1		Reserved
Bit 2	BUS-Local	UMC accepts control commands from a device on the switchgear control network, eg. MView.
Bit 3		Reserved
Bit 4		Reserved
Bit 5		Reserved
Bit 6		Reserved
Bit 7	Remote	UMC accepts control commands from DCS only

Table 24 Extended Status Byte 61

9. Troubleshooting and Maintenance

9.1 Digital Gateway LED Indication

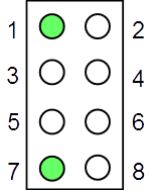
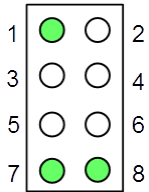
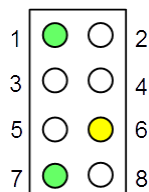
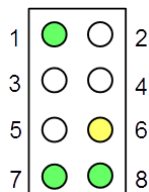
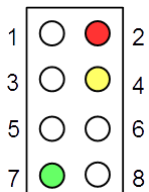
LED indication	Description	Additional Information / Actions
	Digital Gateway is running Ok	
	Digital Gateway is running Ok	LED 8 Digital Gateway is Primary in Dual Redundant configuration.
	Digital Gateway is running Ok	LED 6 DCS communication active
	Digital Gateway is running Ok	LED6 DCS communication active LED 8 Digital Gateway is Primary in Dual Redundant configuration.
	Digital Gateway missing application files	Possible cause could be a interrupted or disturbed communication between MNavigate and Digital Gateway while downloading. Please use MNavigate to download the Digital Gateway configuration again.

LED indication	Description	Additional Information / Actions
	<p>Error in Digital Gateway XML Configuration file</p>	<p>Possible cause could be a interrupted or disturbed communication between MNavigate and Digital Gateway while downloading.</p> <p>Please use MNavigate to download the Digital Gateway configuration again</p>
	<p>Error in Digital Gateway XML Parameter file</p>	<p>Possible cause could be a interrupted or disturbed communication between MNavigate and Digital Gateway while downloading.</p> <p>Please use MNavigate to download the Digital Gateway parameter again</p>
	<p>Internal Digital Gateway error</p>	<p>Digital Gateway is not able to create internal database.</p> <p>Please reboot the Digital Gateway. If that doesn't resolve the problem use MNavigate to download the Digital Gateway configuration again.</p>
	<p>XML file missing</p>	<p>During startup Digital Gateway is checking if all required xml files are available. In case of a missing file that error is indicated.</p> <p>Please use MNavigate to download the Digital Gateway configuration again.</p>
	<p>Network configuration error</p>	<p>Digital Gateway is not able to configure the IP settings as mentioned in configuration file e.g. due to wrong setting of Default Gateway parameter for that Ethernet Interface.</p> <p>Please use MNavigate to check the settings and download the Digital Gateway configuration again. If a download is not possible please use a flash card reader (ref. to MNavigate Help or MNavigate Manual).</p>

LED indication	Description	Additional Information / Actions
	<p>General DCS fault (only available if configured)</p>	<p>Please check if Digital Gateway hardware (the identity number) matches to the project specification (e.g. Profibus Digital Gateway <-> Profibus project). Furthermore, the Data Mapping should be checked. Please use MNavigate to download the Digital Gateway configuration or download Mapping file again (ref. to MNavigate Help or MNavigate Manual).</p>
	<p>General DCS fault (only available if configured)</p>	<p>See above LED 8 Digital Gateway is Primary in Dual Redundant configuration.</p>
	<p>General redundancy fault (only available if configured)</p>	<p>Please use MNavigate to check the redundancy status (Redundancy Report) . If a mismatch was found, please download the regarding file. For details please refer to MNavigate Help or MNavigate Manual.</p>
	<p>General redundancy fault (only available if configured)</p>	<p>See above LED 6 DCS communication active</p>

Table 25 Digital Gateway LED indication

9.2 Troubleshooting

Problem	Solution
No access to Digital Gateway with the web interface or MNavigate	Check if the correct IP address in the address bar of the web browser has been entered.
	Check if the Digital Gateway is powered on and no fault indication is on the LED indication of Digital Gateway.
	Check if the Web Server option is activated. This option is customer project specific and can only be enabled using MNS Engineering Tools. If available, it can be used to check communication to the Digital Gateway.
	Check if the network configuration is correct; use a ping command to verify that the Digital Gateway is reachable. Open a command window on the PC: <ul style="list-style-type: none"> Start / Run, then type in "cmd" and click Enter
	
	<ul style="list-style-type: none"> Enter the ping command with the correct IP address of Digital Gateway: ping xxx.yyy.zzz.aaa
	
	<ul style="list-style-type: none"> If no reply is received, check the cable connection of the PC or MView and Digital Gateway. If a reply is received the connection is ok.
	
	<p>If the Digital Gateway is still not reachable;</p> <p>Remove the CF card from Digital Gateway, insert the CF card into a card reader connected to MNavigate and write the Digital Gateway data again to the CF card.</p> <p>Ensure that correct address settings are entered for Digital Gateway.</p> <p>Re-insert the card to Digital Gateway and start Digital Gateway and check communication</p>

Continued on the next page

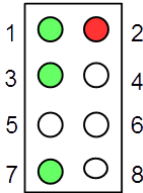
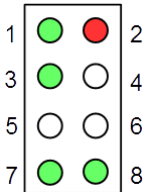
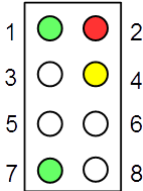
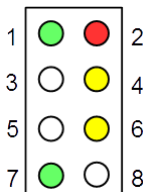
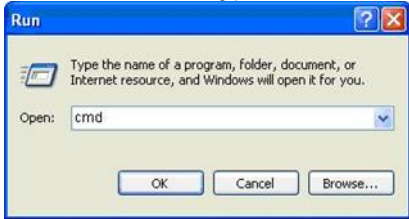
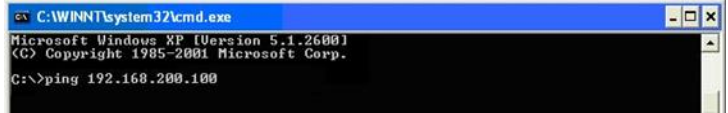
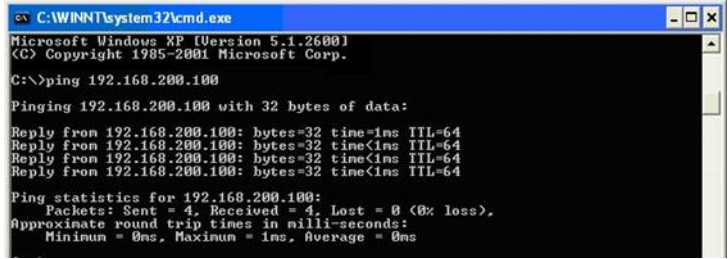
Problem	Solution
No communication between DCS and Digital Gateway	Check if cable connection, shielding, and termination are all in line with the requirements of Profibus standard.
	Check if slave address settings are correctly parameterized in MNavigate and the parameters have been downloaded to the Digital Gateway. Ensure correct settings and no double addressing in the PROFIBUS network
	Check if master configuration in the DCS, please check the correct GSD file is being utilized, and the correct node is being addressed.

Table 26 Digital Gateway Troubleshooting

Revision History

Rev.	Page	Change Description	Date / Initial
-	all	Initial release	2020-08-17 EPDS/MM
0203	07	Dimension of Digital Gateway corrected (chapter 2.1)	2020-10-02 EPDS/FS
0204	44	Remote command revised	2021-01-27 EPDS/mm



Visit us

<http://www.abb.com/mns>